



Composite panels to suit every project



Introduction

Panel Systems has over 35 years' experience in producing high quality composite panels for the construction and related industries. With two large factories in the Sheffield area, which are well equipped with the latest technology, we have the capability to manufacture high quality bespoke composite panels to suit a wide range of specifications.

We have expertise in working with a variety of facing and core materials and can produce insulated panels to meet specific U value acoustic and fire performance requirements.

We offer a full technical support service and assistance with the design of specific panels. All systems are approved to BS EN ISO 9001:2000, to provide added reassurance to customers.

Our facilities

We offer a wide range of facilities to manufacture composite panels, these include:

- 5m x 5m Vacuum Presses
- 4000mm Guillotine
- Press Brake
- CNC Metal Punching
- Aluminium Welding
- CNC Board Machining

Fabrication to close tolerances

We have the ability to cut Styrofoam® core to thicknesses down to 0.5mm and with super tolerances available down to +/-0.05mm. We can also bond thin or gloss materials to lightweight cores, such as Styrofoam®, where thickness and finish are important.

We also work with other core materials, such as Polyisocyanurate, Phenolic Foam and Mineral Fibre Lamella, to suit specific project requirements.

Decorative effects

Our capabilities extend to providing specialist cutting and CNC machining to the face of the panel to save time on site. We can also add decorative effects, such as providing online grooving of the Styrofoam® sheet or panel face to suit specific applications.



Environmental performance

Panel Systems now offers a range of insulation materials that meet with BREEAM requirements. This includes an 'A' rated Styrofoam® as an option for projects that require proven environmental performance. This type of material uses Carbon Dioxide as the blowing agent, with an Ozone Depletion Potential (ODP) of zero and Global Warming Potential (GWP) of one.

At all times, Panel Systems ensures that the customer achieves their required panel size with the minimum of waste. Any Styrofoam® waste created during our production is compacted and recycled.



Edge details to suit all project requirements

Here is an example of some of the most popular designs:

SQ1

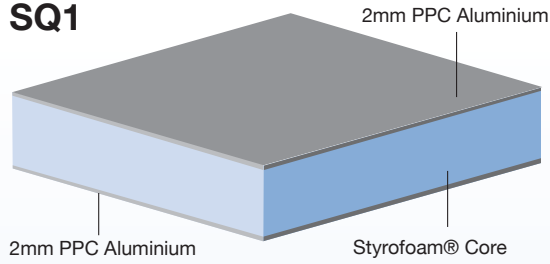

SQ1

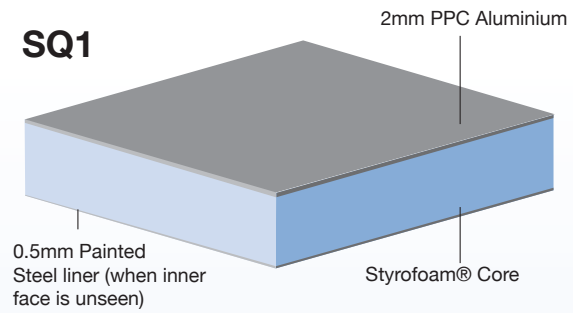

TR1

Toggle fix detail

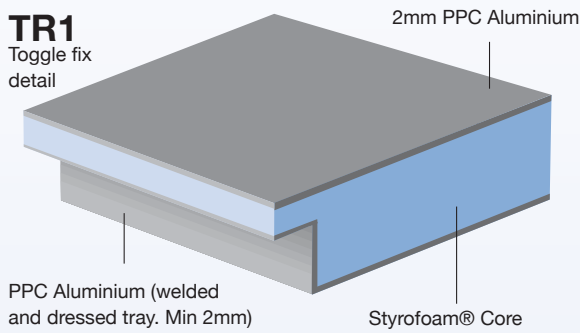

TR1

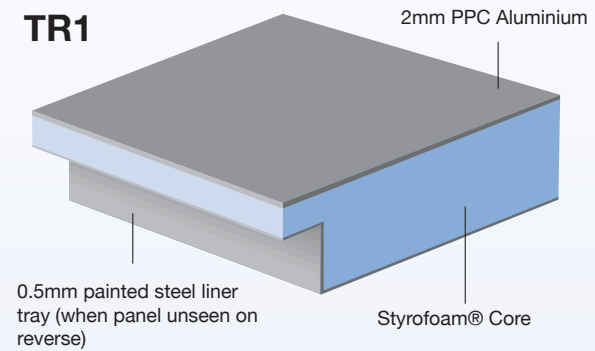

TR1-D

Toggle fix detail

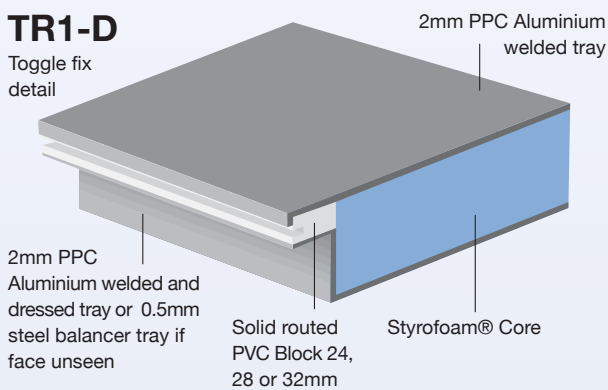

TR5a

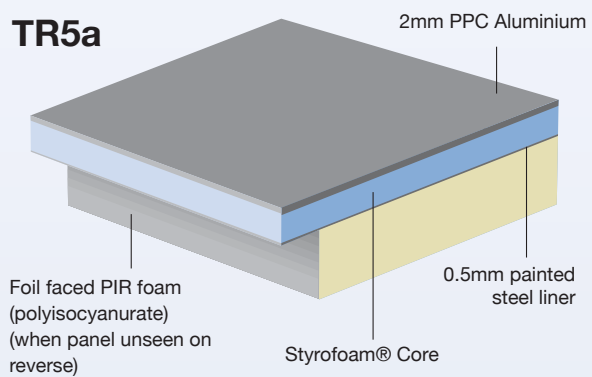

CD1

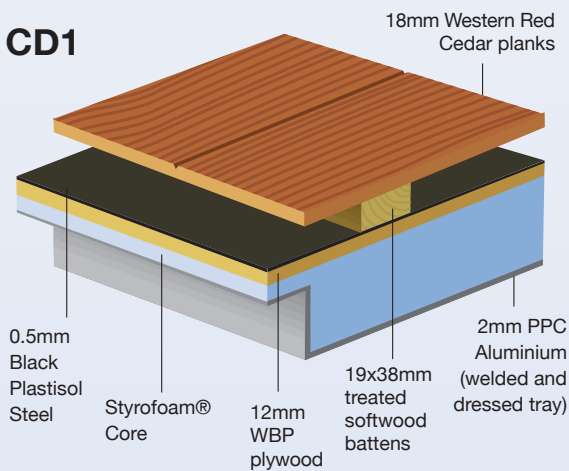

CD2

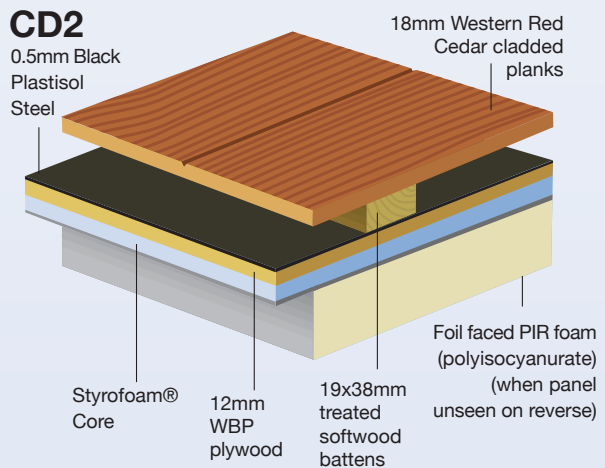

This is just an example of the wide range of edge details that are available from Panel Systems. Bespoke edge details are available on request.

For more information, contact the technical department on 0114 249 5635.

Technical specifications

Composite panel U Value Calculation Table (W/M2K)

U Value required (W/M2K)	1.8	1.2	1	0.8	0.45	0.4	0.35	0.3	0.25	0.2	0.15
Styrofoam® LB K Value 0.027 to 0.028	11mm	19mm	23mm	30mm	55mm	63mm	72mm	84mm	102mm	130mm	175mm
Styrofoam® 'A' Extruded Polystyrene K Value 0.0335 to 0.0355 (BREEAM Compliant)	13mm	22mm	28mm	36mm	71mm	82mm	93mm	111mm	133mm	162mm	217mm
Phenolic Foam K Value 0.022	8mm	14mm	18mm	23mm	43mm	49mm	56mm	66mm	79mm	100mm	132mm
Polyisocyanurate (PIR) K Value 0.023	9mm	16mm	20mm	26mm	49mm	55mm	64mm	75mm	90mm	113mm	156mm
Mineral Fibre Lamella K Vale 0.041	16mm	27mm	34mm	44mm	83mm	94mm	110mm	128mm	157mm	200mm	267mm

Composite panel insulation core selection data table

Performance Criteria	Styrofoam LB-X	Styrofoam LB-A	Phenolic	Mineral fibre Lamella	Polyurethane	Polyisocyanurate (PIR)
LPCB recognised option available			•	•		•
BREEAM compliant option available		•	•	•	•	•
Fire resisting properties			•	•		
Fire retardant additive	•	•	•	•	•	•
Solid PVC Edge spacer required			•	•		
CFC & HCFC Free option	•	•	•	•	•	•
Accoustic / Sound reducing properties				•		
Approx Thermal Conductivity (K Value)	0.027	0.036	0.022	0.041	0.023	0.023
Density (Kg/M3)	33	32	37	105	35	33
Compressive Strength (KPA)	300	300	150	40	220	210
Reaction to fire (DIN 4102)	B1	B1	B2	A1	B3	B2
Class 'O' to building regs?	no	no	yes	yes	no	no

Performance options:



Fire

Fire resistance is a key requirement of many construction projects and we work with specifiers to meet project needs. This includes the selection of specific facing and core materials that have fire retardant properties, where necessary.



Thermal

Panel Systems will recommend use of Styrofoam® as a core insulation material, unless another material is specified. The company's technical team can advise on meeting specific U values to comply with thermal performance requirements and the ability to achieve a low carbon footprint for a building.



Sound

Panels can be specified that help to reduce sound attenuation. We can advise on meeting sound requirements for projects in industrial, urban or city centre areas to enhance the acoustics of a building and minimise noise disturbance.

Composite panel construction

Facing material options:

Polyester Powder Coated Aluminium
(InterPon D and Syntha Pulvin coatings available)

Plastisol Steel

Trespa

Exterior Laminate

GRP

Rockpanel

Anodised Aluminium

Building Boards

Cores:

Styrofoam®

Polyisocyanurate

Phenolic Foam

Mineral Fibre Lamella

Polyurethane

Polystyrene

To obtain a quote, please contact the sales office direct on 0114 249 5635 or email: sales@panelsystems.co.uk

www.composite-panel.co.uk

Case Studies



Novotel, Edinburgh

The four-star Novotel Edinburgh Park hotel was given a striking look due to Panel Systems' Aluglaze® aluminium clad panels. The insulated infill panel consisted of a Styrofoam® core sandwiched between two robust polyester powder coated aluminium faces. Aluglaze® was chosen as it offers excellent UV characteristics, which means it will retain its striking colour for decades, without fading.



Premier Inn, Chester

Aluglaze® panels from Panel Systems were the first choice for the new Premier Inn Hotel in Chester. These aesthetically pleasing aluminium glazed panels were specified to create the curtain walling to the building, providing a contemporary, light and airy feel, whilst ensuring that thermal performance values could be met. Use of these panels ensured a stunning look to a contemporary building.



Monkseaton School, York

Bespoke Aluminium panels were chosen for the exterior of the £20m Monkseaton High School in North Tyneside. The panels were specified with metallic silver Syntha pulvin powder coated aluminium faces to meet the specifiers' high aesthetic requirements. The powder coated finish on the panels provided a tough surface which will retain its visual appeal and enhance its weather resistance.



Granary Wharf, Leeds

Western Red Cedar panels were chosen for 'Waterman's Place' – a prestigious city centre apartment block in the regenerated Granary Wharf area of Leeds. Panel Systems supplied bespoke Cedar panels, which met the architect's brief for the use of sustainable natural materials, but that could withstand the wind loadings on the exposed elements of the upper floors of the building. The project also required a panel that could fit effectively with the glazing system and create a robust weathertight seal.



Taylors of Harrogate Head Office, Harrogate

Western Red Cedar cladding panels were supplied for a new extension at the headquarters of the world famous tea and coffee brand Taylors of Harrogate. The architect was looking to create a completely natural look that complemented its surroundings. Panel systems created a panel that consisted of varying widths of cedar cladding which were then attached to a load bearing composite panel via treated softwood battens. The end result was a fully insulated panel which ran flush with the glazing system.



MacDonalDs Hotel, Manchester City Centre

A former BT building, the MacDonalDs Hotel in Manchester was given an exciting new look with Aluglaze® aluminium infill panels from Panel Systems. As well as providing the building with a striking contemporary look, the Aluglaze® panels significantly improved the thermal performance of the building, which was due to an insulating core of Styrofoam®. The building now enhances this high profile area of Manchester City Centre.



Aluglaze

Manufactured by **Panel Systems**

Aluglaze® is an insulated infill panel comprising polyester-coated aluminium, which is bonded to a core of Styrofoam®. A premium quality panel, Aluglaze® is typically specified when aesthetic considerations are paramount. Interpon 'D' RAL and Syntha Pulvin colours are available.

- Supplied cut to site sizes
- Thicknesses to suit glazing system
- Styrofoam® 300 compressive strength
- Moisture resistant



Styroglaze

Manufactured by **Panel Systems**

Styroglaze® is an insulated panel comprising Plastisol Steel which is bonded to a core of Styrofoam®. This innovative panel can be manufactured to suit all glazing systems and provides a cost effective pre-finished insulated panel.

Styroglaze's low maintenance surface gives excellent durability against UV light and Class '1' performance against surface spread of flame.



Insuglaze

Manufactured by **Panel Systems**

Insuglaze® is an insulated infill panel comprising high pressure laminate, which is bonded to a core of Styrofoam®.

These panels are designed to provide high performance and strong aesthetics, making them suitable for use with all window systems, including PVC-U, steel, timber and aluminium.

Customer service

Panel Systems is committed to delivering the very highest customer service. This includes having the capability to meet bespoke requirements and offering a flexible, tailored approach. We are centrally located and well served by main motorway routes, which means we can provide a rapid response to customer needs. We pride ourselves on providing a complete project management service, from offering design and technical support, through to advising on performance requirements and the production and delivery of materials. Nothing is too much trouble, which is the reason we have built such a strong reputation over the years.

Panel Systems

Welland Close,
Parkwood Industrial Estate,
Rutland Road
Sheffield S3 9QY
Tel: 0114 275 2881
Fax: 0114 278 6840

www.composite-panel.co.uk
sales@panelsystems.co.uk